

~ UIL/NCAA SIX-MAN FOOTBALL RULES COMPARISON ~

General: Texas Six-Man Football Rules are the same as NCAA Football Rules Except for the following variations. (Note: NCAA Rule References are indicated in parenthesis).

NCAA RULE	SIX-MAN RULE VARIATION
(1-1 & 2)	1. Each team has six players. Unless necessary to use the eleven-man field, the six-man field is 80 yards by 40 yards, with the 40 yard line being the center of the field. The two inbound lines (hash marks) are 40 feet from the sidelines. There will also be marks that are measured 13 feet from the sidelines. Goal posts are 25 feet apart and the crossbar is 9 feet above the ground.
(1-1-3)	2. When one team is 45 or more points ahead at the end of the first half or if a team achieves a 45 point lead during the second half, the game is ended immediately.
(3-2)	3. Length of quarters is 10 minutes; between quarters; 2 minutes. Between halves, 15 minutes.
(4-1-3)	4. During a try after touchdown the ball becomes dead when Team B gains possession or it is obvious that a kick is unsuccessful.
(5-1)	5. Offense must advance 15 yards instead of 10 yards in four downs.
(6-1)	6. Unless relocated by penalty, the kicking team's restraining line on a kickoff is the 30 yard line on a six-man field and the 20 yard line for a free kick after safety. The receiving team's free kick restraining line is 15 yards from the point of kickoff. There is no requirement to have a minimum number of players on either side of the kicker.
(6-1)	7. The ball must travel 15 yards on a kickoff (or place kick/punt after a safety) or be touched by the receiving team before members of the kicking team are eligible to touch it.
(6-2)	8. A free kick out of bound between the goal lines untouched inbounds by a player of Team B is a foul (A.R. 6-2-1-I-IV). PENALTY—Live-ball foul. Five yards from the previous spot or the receiving team may put the ball in play 20 yards beyond Team A's restraining line at the inbounds spot (S19).
(7-1-3)	9. Unless the ball is kicked or forward passed, it may not be advanced beyond the neutral zone until AFTER AN EXCHANGE has been made between the receiver of the snap and another player. EXCEPTION: Any player of Team A may advance a loose football after it has been touched by a Team B player. PENALTY: 5 yards plus loss of down (illegal procedure) from previous spot (S19 & S9). An exchange is completed when possession of the football is gained by a receiver of the snap, given up voluntarily or involuntarily by the receiver of the snap, and possession is regained by another player of Team A.
(7-1)	10. If the snap is muffed and a Team A player catches or recovers the ball beyond the neutral zone, he may not advance it. PENALTY: Loss of down (illegal procedure) from previous spot (S19 & S9), 5 yards from the previous spot is also assessed if the Team A player advances the ball. If a Team A player catches or recovers the muffed snap behind the neutral zone, he may legally advance it only after a legal exchange.
(7-1-3)	11. At least 3 Team A players shall be on their line of scrimmage at the snap.
(7-1-6)	12. The ball may be handed in any direction to any player during a scrimmage down behind the neutral zone. A linesman may receive a forward hand-off at any time and is not required to be 2 yards behind his line of scrimmage and does not have to face his goal prior to receiving the hand-off. EXCEPTION: The ball may not be handed forward to the snapper through his legs. PENALTY: 5 yards from previous spot and loss of down (S19 & S9).

- (7-3) 13. The ball is dead when a passer catches his own pass (untouched by B), and it is ruled as an incomplete forward pass.
- (7-3) 14. All players are eligible to catch a forward pass, except that a pass is ruled incomplete when caught by the passer (see preceding rule). If a forward pass is thrown to the snapper, it must travel at least one yard in flight.
- (8-1) 15. Field goals count 4 points; successful try, 2 points if successful through place or drop kick and 1 point if successful by pass or run. The defense may not score on a try.
- (8-1) 15. Field goals count 4 points; successful try, 2 points if successful through place or drop kick and 1 point if successful by pass or run. The defense may not score on a try.
- (9-1-2) 16. **When a team is in an offensive or scrimmage kick formation, a defensive player may not initiate contact with the snapper until one second has elapsed after the snap.**

~ APPROVED RULINGS ~

Section 1: Exchanges:

- I. First down and 15 from A's 35. A10 pitches to A28 who muffs the ball. A10 picks it up and runs to A's 45. RULING: Illegal advance by A. Penalize 5 yards plus loss of down.
- II. First down and 15 from A's 25. A10 pitches the ball backward. It strikes B72 and is loose on the ground. A10 picks up the ball and runs to B's 40. RULING: A's ball first down and 15 on B's 40. NOTE: by definition, when the ball strikes B72, it has been touched by Team B player.
- III. A15 hands the ball to A40. While still behind the line A40 hands the ball forward to A15 who advances beyond the line for a ten yard gain. RULING: Legal advance by A15.
- IV. A12 receives the snap and possesses the ball. He hands the ball forward to A60, the snapper by handing it back between his legs. A60 advances 5 yards. RULING: Illegal Advance by Team A. PENALTY: 5 yards and loss of down.
- V. A15 receives the snap and hands off to A38. A38 fumbles the ball and it is picked up by A45 (1) behind the line of scrimmage; (2) beyond the line of scrimmage. A45 advances for 10 yard gain. RULING: A legal exchange has been made. A45 may advance the football in (1) & (2).
- VI. A12 receives the snap and pitches the ball to A45 who muffs the pitch and is attempting to catch the ball (bobbling it) as he crosses the neutral zone. A45 then catches the ball and advances for a five yard gain. RULING: Legal advance.
- VII. A's ball first down and 15 at A's 20 yard line. A8 muffs the snap. It is picked up by A25 behind the neutral zone and advanced to A's 30. RULING: Illegal advance by A. A's ball at the point of recovery. Penalize 5 yards plus loss of down from the line of scrimmage. No legal exchange has been made since A25 was the first to possess the ball after the snap and then advanced the ball beyond the neutral zone without an exchange.
- VIII. A's ball second and 5 at A's 24. A13 receives the snap and fumbles the hand-off to A30. A30 recovers the fumble and hands the ball back to A13 who advances it to A's 32. RULING: A's ball first down and 15 at the 32 yard line.
- IX. A10 muffs the snap from A50. The ball rolls a few yards beyond the neutral zone where A6 (1) picks up the ball and advances; or (2) falls on the ball for the recovery. RULING: (1) Illegal, 5 yards previous spot plus loss of down. Penalty marker is dropped, play continues. (2) Legal recovery, no foul, the ball is returned to the line of scrimmage, loss of down. A legal exchange has not been made prior to advancement of the ball beyond the line of scrimmage.

- X. A25 receives the snap and immediately throws a backward pass to A40 who muffs the pitch. A40 scoops up the ball from the ground and advances beyond the neutral zone. RULING: Legal, a backward pass has been thrown and a legal exchange has been completed.
- XI. A's ball 1st and 15 from B's 22. A10 receives the snap and attempts to hand the ball to A20. The ball is fumbled and A70 recovers at B's 19. RULING: Illegal. PENALTY: 5 yards plus loss of down. A's ball at B's 27.
- XII. A's ball 4th and 1 at B's 30. A10 receives the snap and fumbles the hand-off to A22. A22 picks up the football and advances to B's 25. RULING: Ball is dead when A22 picks up the football. No advance is allowed. NCAA Rule 4-1-3-k applies and prohibits advance. A10 may pick up the loose ball and complete an exchange for a legal advance.

Section 2: Passing

- I. A15 attempts a forward pass which is batted in the air by B73. A15 catches the ball and advances it 10 yards. RULING: Legal. Ball was touched by B.
- II. First and 15 yards to go for A at their 15 yard line. A9 hands the ball forward to A30. A30 runs to the left and passes the ball to A60 while still behind the line of scrimmage. RULING: Legal pass by A30.
- III. A15 receives the snap and retreats 10 yards to his own 20 yard line. Due to a heavy pass rush he immediately passes the ball to A50, his snapper, who is standing on the 19 yard line. RULING: Legal pass since the ball traveled at least one yard when passed to the snapper.
- IV. A8 attempts a pass at the line of scrimmage. B75 tips the ball and it is caught by A55, the snapper, at the line of scrimmage. The ball has only traveled 1/2 yard in the air. RULING: The tipping by B makes A55's reception a legal catch and A55 may advance the ball.
- V. A's ball 4th and 4 at B's 22. A10 throws a pass which strikes A73 and bounces into the air. A10 catches the ball and advances 5 yards where A10 fumbles the ball. RULING: Incomplete forward pass. B's ball 1st and 10 at their 22. (Six-Man Rule variation No's 12 & 13)

Section 3: Other Plays

- I. Team A lines up at the line of scrimmage with three men on the scrimmage line next to each other in a three point stance. A80 located on the right side of the snapper raises up and shifts out 7 yards. RULING: Since A80 is at the end of the line this is a legal shift.
- II. Team A lines up with four men on the line of scrimmage next to each other in a three point stance. A62 who is covered up by A80 (1) raises up from his 3 point stance before the snap; or (2) receives a forward hand-off and advances 4 yards; or (3) catches a forward pass 10 yards beyond the line of scrimmage. RULING: (1) False start. (2) & (3) Legal.
- III. Team A lines up with 4 men on the scrimmage line next to each other. A88, on the end line, leaves his position and goes in motion before the snap. At the snap, he is (1) moving toward his opponents goal line; (2) moving away from his opponents goal line and 2 yards behind the line of scrimmage. RULING: (1) Illegal motion since A88 cannot be moving toward his opponents goal. (2) Illegal motion by A88. He must set for one second after leaving line. A lineman may not be in motion at the snap.
- IV. Team A's kickoff from their 30 yard line rolls out of bounds untouched by Team B at B's 38. RULING: B may snap the ball at their own 38, 30, or accept the penalty against A for illegal procedure.
- V. B is leading 60-19. They return the 2nd half kickoff 65 yards for a touchdown. RULING: Game ends.
- VI. B is leading 50-10 in the second half. B intercept's A's pass and returns it 16 yards for a touchdown. B44 clips on the run back. RULING: If A declines the penalty the game ends and there will be no try for point.
- VII. A's ball fourth down and 5 from their 20 yard line. A14 punts the ball which is blocked and goes straight up in the air. A45 catches the punt behind the line of scrimmage and advances to A's 40 yard line. RULING: Legal advance by A, first down and 15 yards to go.

VIII. Team A attempts a try from any legal point and:

- (1) Team B recovers a legal fumble, picks it up and advances the ball into Team A's end zone; or
- (2) Team B intercepts a fumble or forward pass and advances the ball into Team A's end zone; or
- (3) Team B blocks the try, gains legal possession and advances the ball into Team A's end zone; or
- (4) Team B blocks the try and A12 picks up the ball and advances into Team B's end zone.

RULING: No score, ball is dead when it is obvious that the kick is unsuccessful.

SIX-MAN FOOTBALL GOALPOST DIMENSIONS

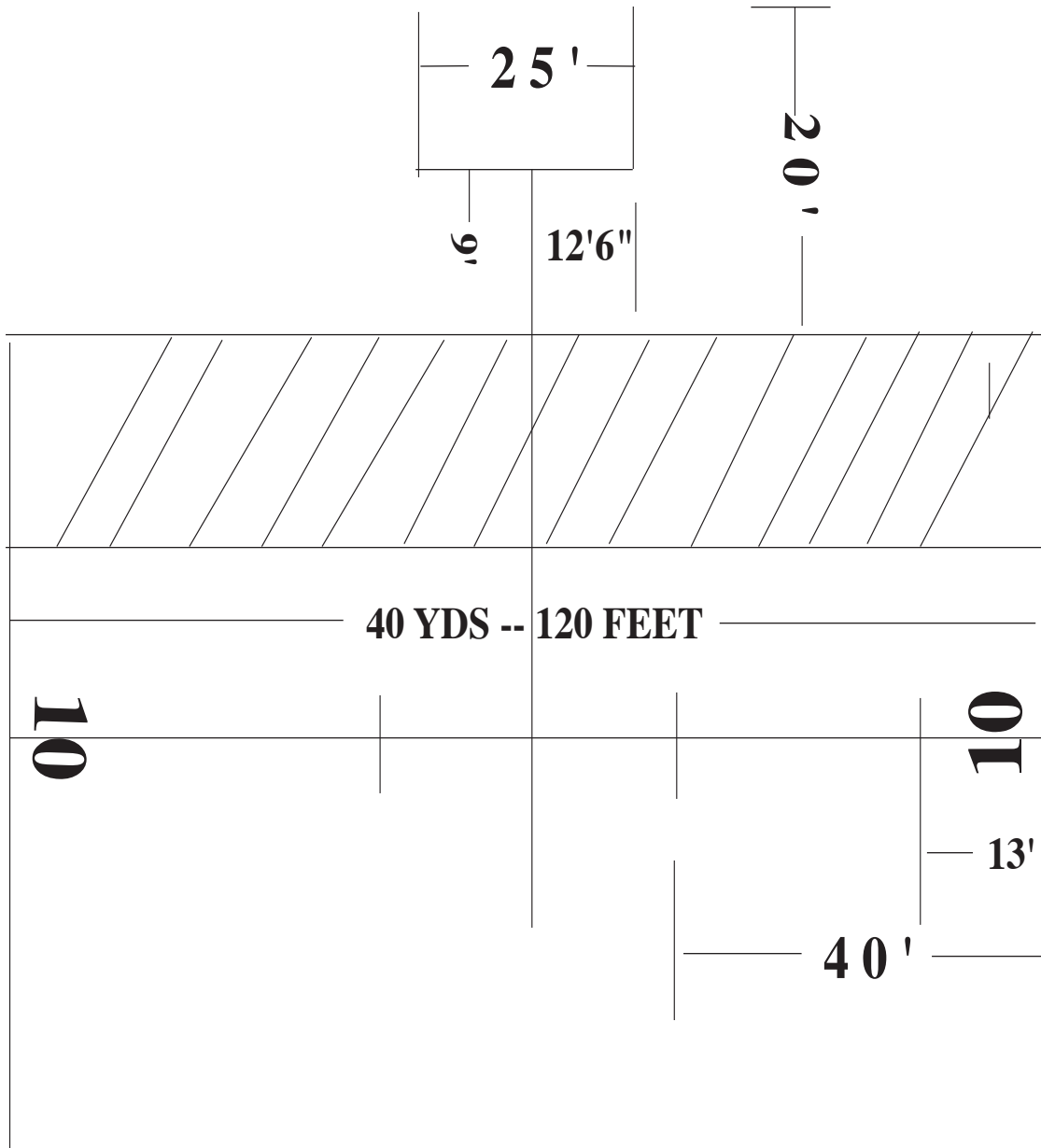

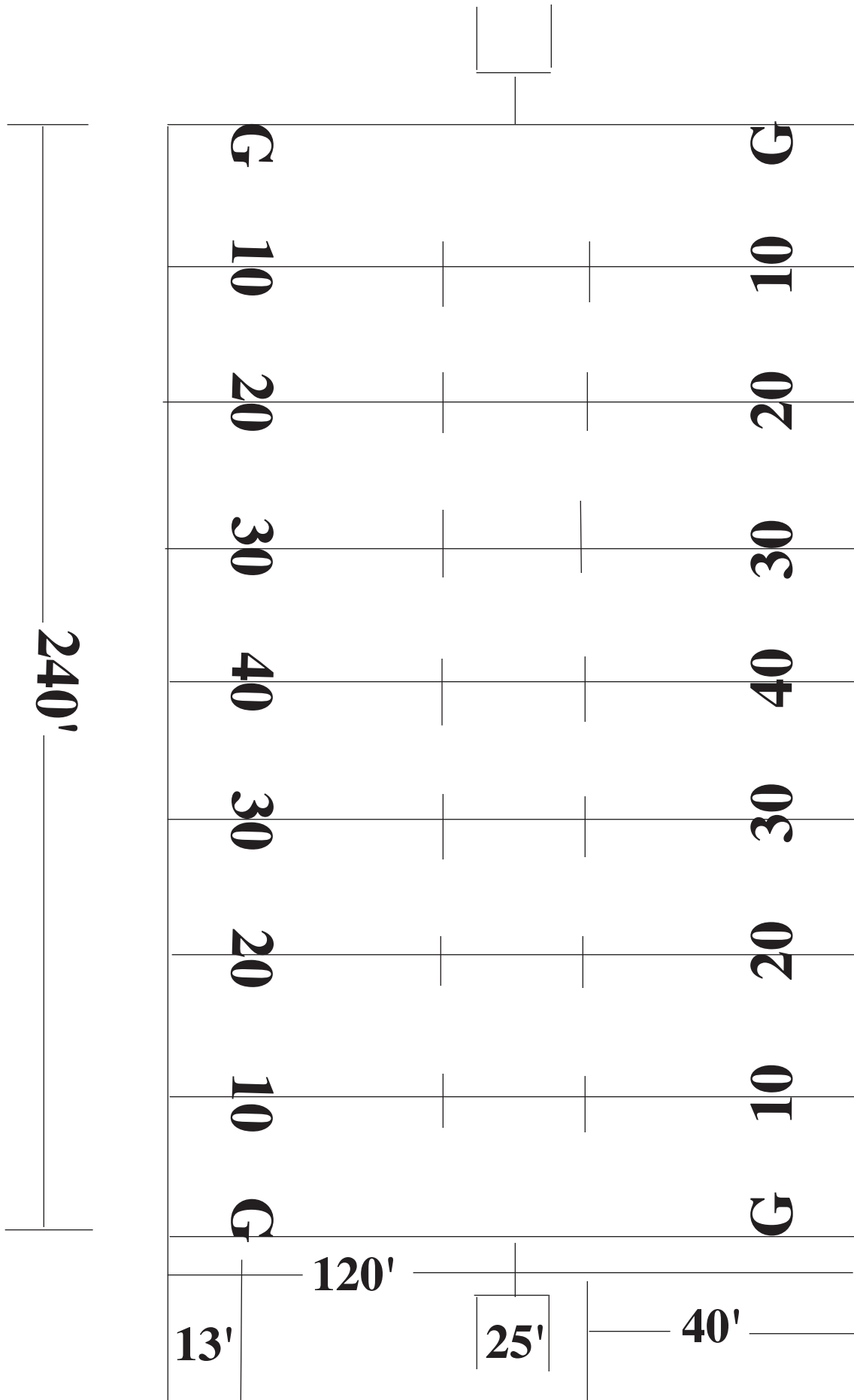

**9 YARDS MARKS ARE 13 FEET FROM SIDELINE -- TOP OF NUMBERS
HASH MARKS ARE 40 FEET FROM SIDELINE**